

# FujiMAC Air Pump



Model	MAC40RII	MAC60RII	MAC80RII	MAC100RII	MAC120RII	MAC150RII	MAC200RII	MAC250RII	MAC300RII
Rate Voltage	230~240V								
Air Flow	40L/min	60L/min	80L/min	100L/min	120L/min	150L/min	200L/min	250L/min	300L/min
Pressure	12kPa	15kPa		18kPa		20kPa			
Outlet Pipe	13mm (external dia. 18mm)				20mm (external dia. 26mm)				
Weight	5.0kg					9.0kg			
Power Consumption	27W	35W	49W	68W	86W	100W	140W	186W	250W
Noise level	32db	35db	36db	39db		41db	43db	48db	50db

\*Numerical value of the table in the case of 230V 50Hz

## 1. Long Life

New FujiMAC has successfully minimized the housing temperature rise by only 30°, so FujiMAC Air Pump will live longer!

## 2. Energy Efficient

New FujiMAC Air Pump are the most efficient air pump of only 140W power consumption for MAC200RII. You can greatly reduce the

## 3. Made in Japan

All FujiMAC Air Pump are developed and made in Japan at our factory. Only FujiMAC is Made in Japan!

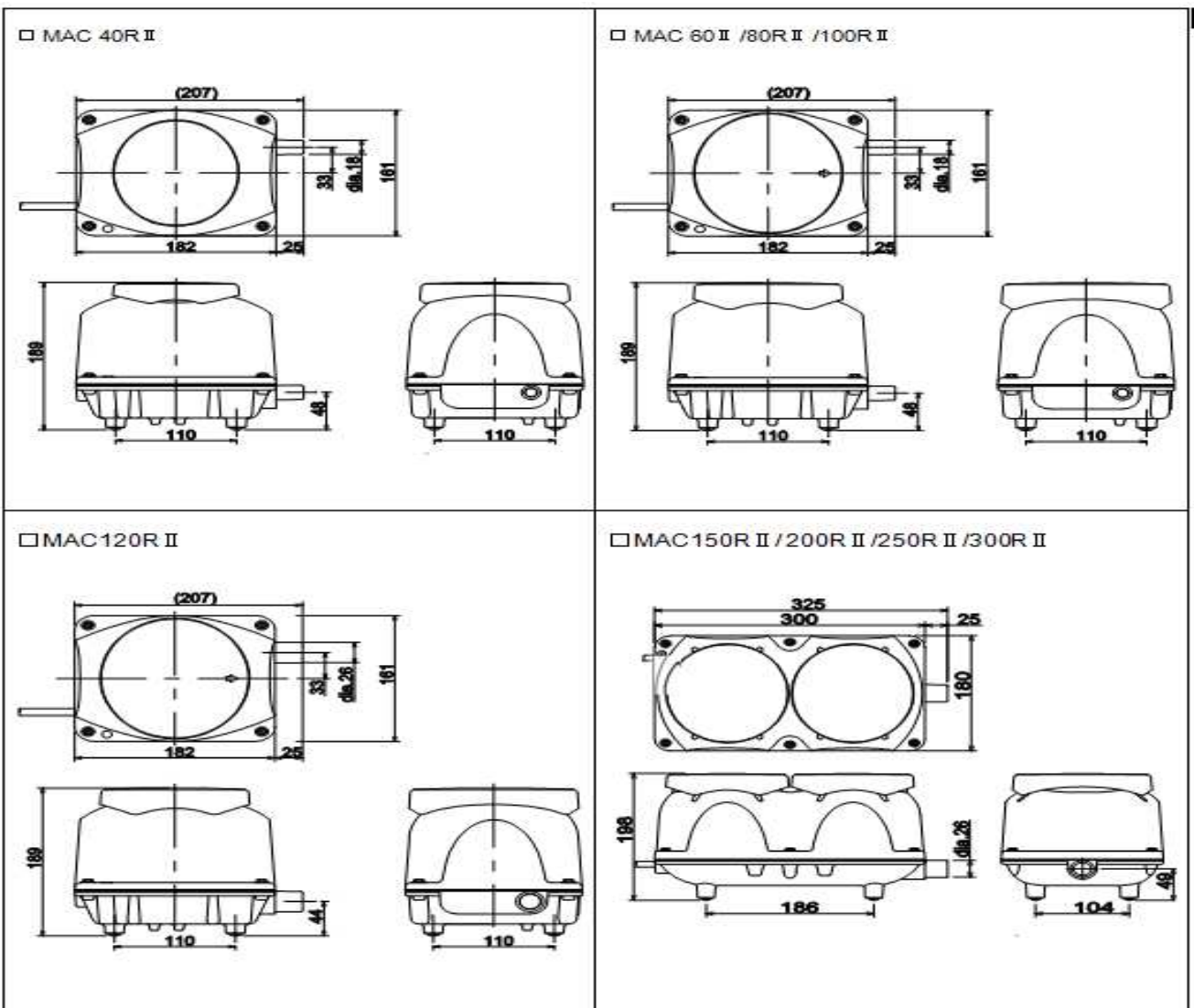

**FujiMAC Series Performance Curve -230V50Hz**  
 MAC40R II / 60R II / 80R II / 100R II / 120R II / 150R II / 200R II / 250R II / 300R II

